

TABLE OF CONTENTS

1) Introduction.....	2
2) Unpacking the Monoblocks.....	2
3) Connecting the Monoblocks.....	3
4) Operation of the Monoblocks_.....	4
5) Setting the tube bias.....	5
6) Troubleshooting	8
7) Registration card.....	8
8) Fuse values.....	8
9) Specifications.....	8
10) Warranty.....	9

INTRODUCTION

Congratulations on your purchase decision! We at Rogue Audio truly believe that our amplifiers provide the “smartest” value in high-end audio. If you have never owned a vacuum tube amplifier you will be thrilled by the silky-smooth sound and incredible detail that only a tube amplifier can provide. And with the M180/M180 Dark Monoblock amplifiers, you can be sure that you are getting the very best in tube amplification. We at Rogue Audio are extremely proud of our products and want you to enjoy them to their fullest potential. So please, take the time to read through this short manual so that you can be confident that you have set up your amplifier properly.

UNPACKING THE M-180/M-180 DARK POWER AMPLIFIERS

Tools required: none

WARNING - This amplifier uses voltages that could cause injury or death. Never open the amplifier while it is plugged in, and always wait at least one hour after turning the unit off to unplug and open the unit. *Lethal* voltages can remain in the electronics after the unit is unplugged.

Your amplifiers have been painstakingly inspected for cosmetic flaws during and after assembly. In order not to damage the cosmetic appearance of the amplifiers it is important that you follow the unpacking instructions carefully.

1. Carefully lift the amplifier out of the box, and remove the foam pads and plastic bag.
2. Remove the banding holding the tube cage in place. Lift off the tube cage and remove the foam pad holding the tubes in place. This foam pad is required during shipment to prevent damage to the output tubes.
3. Remove the shipping pallet from the bottom of the amp. The pallet serves two purposes. First, and foremost it acts to tie down the mechanically isolated transformer platform. Secondly, it provides strength to the main chassis. Both of these are critical to ensure that no damage occurs in transit.
4. Save the packing materials. The packing materials and box have been carefully designed to protect your valuable equipment during shipping so you don't want to throw them away.
5. Using a glove or a clean dry cloth, straighten any tubes that may have tilted during shipment. Ensure that all of the tubes are fully seated in their ceramic sockets.

CONNECTING THE MONOBLOCKS

Connecting the monoblocks to the loudspeakers:

The rear panel has binding posts for both 4 and 8 ohm loudspeakers as shown in Figure 1. In general, if your speakers are rated at less than 6 ohms, use the 4 ohm taps and use the 8 ohm taps if they are 6 ohms or greater.

CAUTION – Do not operate the amplifier unless it is connected to a loudspeaker.

Connecting the monoblocks to the preamplifier:

There are two types of input connections on the rear panel of the amplifiers:

- 1) Fully balanced XLR type input.
- 2) RCA input

The input connections can be made using either the XLR or RCA input, depending on your system setup.

Note that if you have a variable output CD player you can choose to drive the amplifiers with it directly.

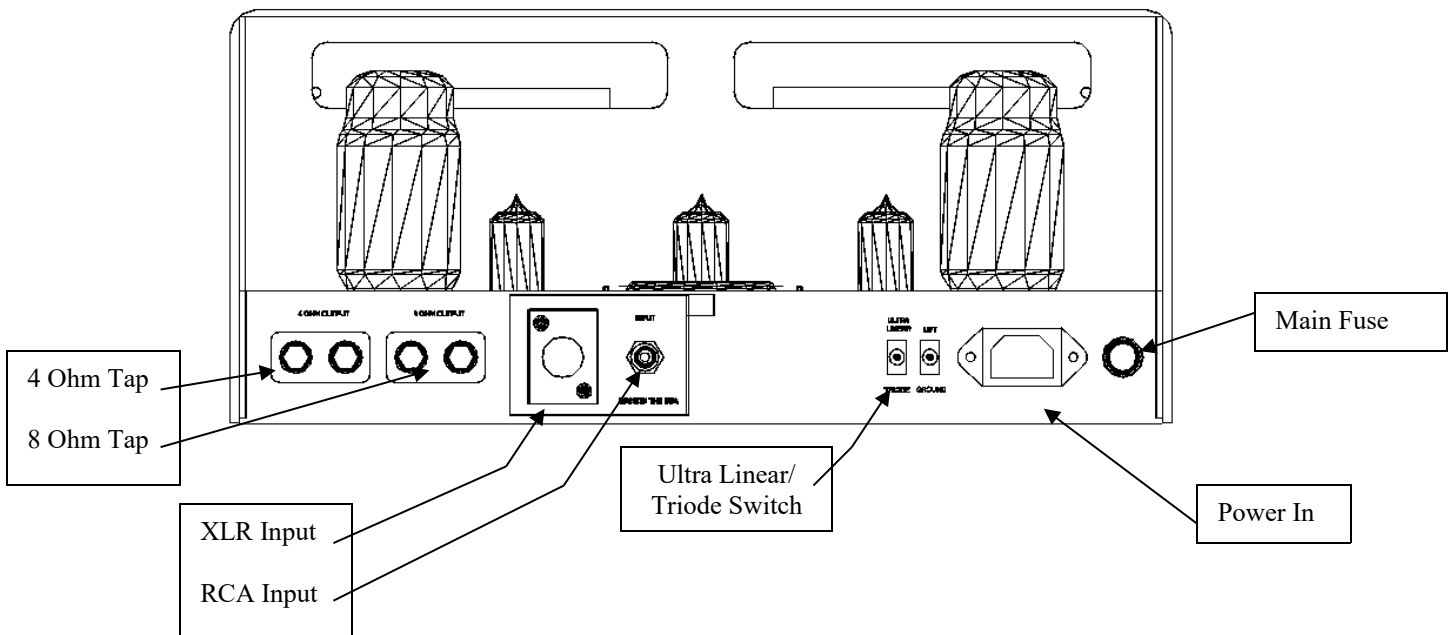

Figure 1. Rear panel layout

Connecting the amplifiers to the power outlet:

Connect the IEC end of the detachable power cord provided to the amplifier, and plug the opposite end into corresponding outlet. It is recommended that both amplifiers and your preamp are plugged into the same wall outlet if possible (perhaps using a power outlet strip). This is to avoid creating a ground loop.

Amplifier Location:

The monoblocks are an open tube design and depends on natural convection flow patterns for proper cooling. To ensure proper cooling, the unit should be located in a position so that the airflow is not impeded. Since there are vents on the bottom of the unit, it should always rest on a firm surface to ensure adequate spacing between the resting surface and bottom of the unit. In addition, the unit should not be placed in an enclosed shelf, and should have a minimum of 6 inches of free space above it.

OPERATION OF THE MONOBLOCKS

After all proper connections have been made, you are now ready to turn the amplifiers on. The power on/off switch is on the front of the amp. Some preamplifiers and sources can generate dangerous transients that can damage loudspeakers. To avoid letting dangerous transients reach your loudspeakers turn your system on in the following order:

- 1) Turn on all sources (CD, tuner, etc.) that you will be using.
- 2) Turn on the preamplifier.
- 3) Wait until preamp has stabilized.
- 4) Power up the amplifiers
- 5) Select listening source and play music

When powering down your system turn the amplifiers off first.

Note – **Important!** After turning off the amplifiers, wait at least one minute to turn them back on. Do not turn them on then off and then on again in quick succession. Doing this will not allow the power supplies to discharge between on/off cycling and may result in transient noises.

Triode/Ultralinear switch:

This switch is located on the back panel of the amp. See Figure 1. The output transformer of a tube amplifier acts as the electrical interface between the very different impedances of the loudspeaker and the tube circuitry. There are three fundamental ways that the output transformer can be connected to the tube circuit.

- 1) Tetrode or Pentode connection – In this configuration, the highest power level is achieved but at the expense of significantly higher distortion levels. Practically speaking, this mode of operation is sonically inferior and has been disregarded in the M180 design.
- 2) Triode connection – With this configuration, the lowest level of distortion is achieved but at the expense of output power. In the case of the M180's, the power level in triode is high enough that it will likely provide plenty of power for almost any speaker load.
- 3) Ultralinear operation – With this configuration, power levels near those of tetrode mode are achieved with low distortion levels that approach those of triode operation. For loudspeakers that demand very high levels of power, ultralinear should provide excellent sound and plenty of power.

The triode/ultralinear switch allows the user to operate the monoblocks in either of the two modes. In general, the sonic differences are subtle but for a given loudspeaker one mode is likely to sound better than the other. There is a complex relationship between the output transformer and the crossover network so try both and see which one works best in your system. This switch can be operated while the amplifier is playing but you will hear a small relay noise through the loudspeaker.

SETTING THE TUBE BIAS

Tools required: bias tool (provided with amplifier)

The output tubes (the big ones) need to be “biased” with a grid voltage that controls the flow of electrical current through the tube. Tube biasing on the M180 amplifiers has been designed to be both simple and effective. On some amplifiers biasing is done for two or more tubes simultaneously. With this method, the total current flowing through the group of tubes may be correct, but the current flow through any individual tube may vary significantly from the optimal value. With the M180 amplifiers the bias is set individually for each tube so that the correct operating point is assured. An added benefit to this approach is that, should a tube fail prematurely, the single tube can be replaced without having to purchase a matched set. Use the following procedure to set the tube bias:

WARNING – There are dangerous and potentially lethal voltages inside this amplifier. Do not touch any part of the amplifier other than as described below. If you are uncertain about any of these instructions, please contact your dealer and have them bias the amplifier for you.

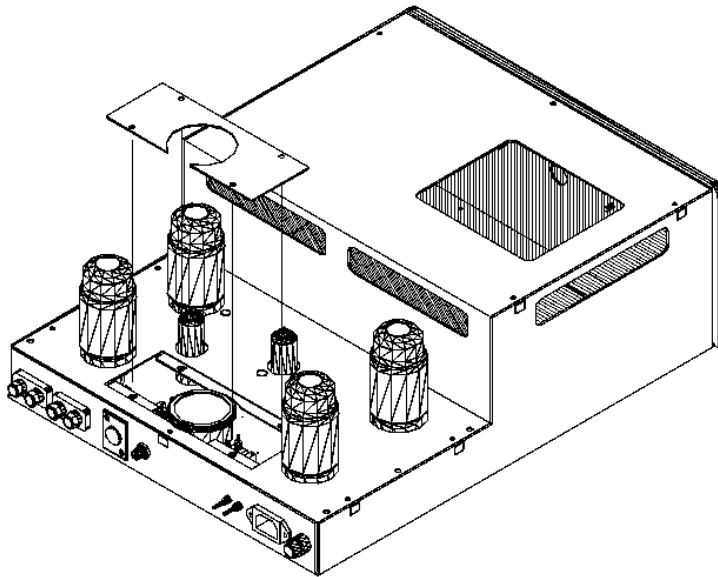

Figure 2. Removable hatchplate

- 1) Allow the amplifier to warm up for at least 30 minutes.
- 2) Turn the preamplifier volume completely off so that no signal is entering the amplifier
- 3) Loosen the 4 captive screws on the top hatch cover.
- 4) Remove the hatch cover.
- 5) Locate the toggle switches and associated small potentiometers (they are gray and have a small screw in the top). There is a set of four in each amplifier. Note the biasing meter.
- 6) Make sure that all of the toggle switches are pointed away from the meter (run position). Begin with any switch, moving the switch into the “set” position. You will see that the meter will rise up to show that the tube’s current is now flowing through the meter.

- 7) Using the bias tool, slowly turn the screw on the potentiometer that is adjacent to the switch until the bias meter reads ~ 40 milliamps (mA). Turn the screw clockwise to lower the bias and counterclockwise to raise the bias. Note that there are two ends on the bias tool. Using the end with the recessed screwdriver will greatly facilitate this operation.

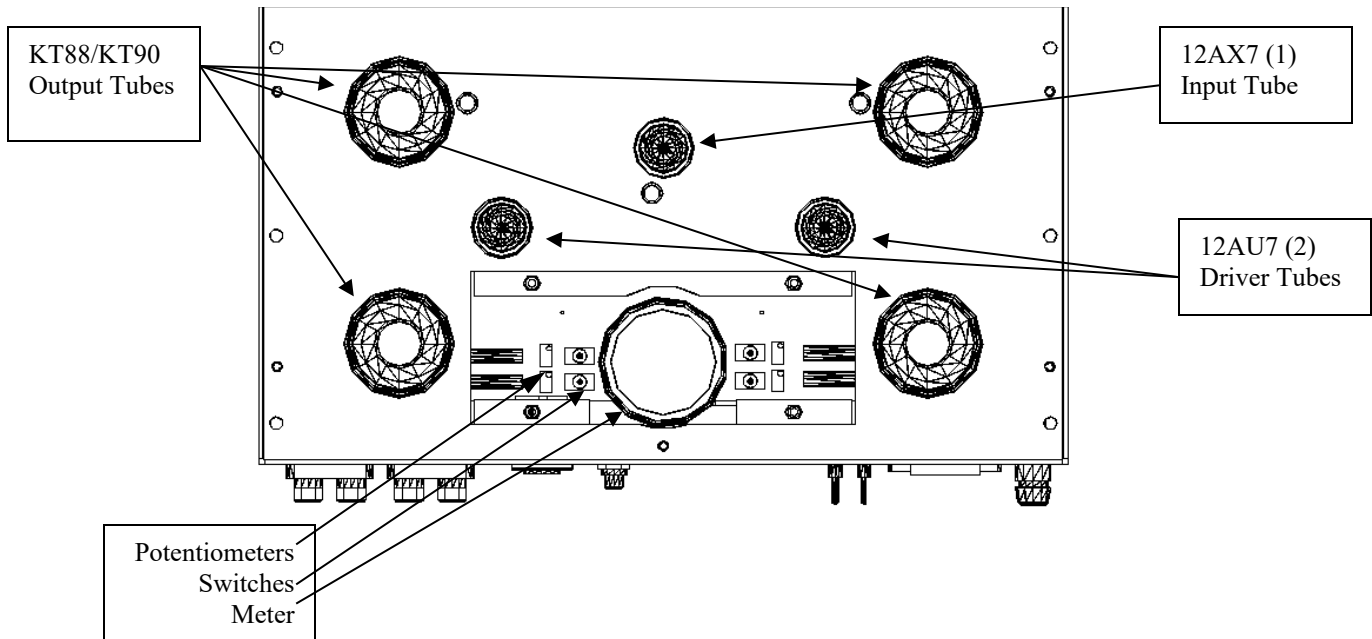

Figure 3. Bias switches and potentiometers

- 8) Flip the switch back into the “run” position thus disengaging the tube from the meter circuit.
- 9) Repeat the above steps for each of the tubes in both amplifiers.

As it is a quick operation, the tube bias should be checked on a regular basis.

TROUBLESHOOTING

Speaker Hum – If hum can be heard from more than a few inches from the loudspeaker, there is probably a ground loop. Ensure both of the amplifiers are plugged into the same outlet. If this fails to cure the hum, call customer service at Rogue Audio for further advice.

Tube will not bias – If the meter provides a reading but the tube will not bias, the tube is probably bad. If no meter reading can be attained, check the fuse (1/4 Amp slow blow). If the fuse is bad, replace the fuse and then set the bias. If the bias will not maintain itself and the fuse blows again, the tube should be replaced.

Bias Meter reading is too high – Check that you do not have two of the bias switches turned on.

Output sounds distorted - Check the bias on the output tubes to ensure that the tubes are operating properly.

OWNER AND WARRANTY REGISTRATION FORM

Included with this manual is an Owner and Warranty Registration Form. Please take a minute to fill out this card and return it to Rogue Audio. This card must be returned within 30 days of purchase to validate the warranty.

FUSE VALUES

Main fuse located on rear panel (1) – 5 Amp slow blow

Tube Fuses (4) – 1/4 Amp slow blow

Power Supply Fuse on PCB (1) – 3/4 Amp slow blow

SPECIFICATIONS

output power	KT-88 150WPC / KT-120 180 WPC
frequency response	5Hz – 50 kHz ± 1dB
THD	< 0.1% typ, < 1% at rated power
input sensitivity	1.0 V RMS
dimensions	14 ½” W x 19” D x 7” H
weight	55 pounds (25 Kg)
shipping weight	60 lbs (27 Kg)
power requirements	115/230V - 50/60Hz

LIMITED WARRANTY

Warranty Period

This product has been manufactured under the highest standards of quality and workmanship. Rogue Audio Inc. (hereinafter "Rogue Audio") warrants this product against defects in material or workmanship as follows:

With the exception of vacuum tubes, Rogue Audio warrants to the original purchaser of this product all parts of this product against defects in material and workmanship for a period of three years from the date of retail purchase. Rogue Audio warrants the vacuum tubes for a period of six months from the date of retail purchase. Any defective parts will be replaced free of charge, excluding shipping and handling.

Proof of purchase in the form of a bill of sale or recited invoice which indicates that the product is within the warranty period must be presented to obtain warranty service. Rogue Audio suggests that the purchaser retain the dealer's bill of sale as evidence of the date of retail purchase.

What's Not Covered

This warranty does not cover cosmetic damage or any damage that results from product misuse, product abuse, installation error, connection to an improper voltage supply, accident, improper maintenance, alterations, modifications not authorized in writing by Rogue Audio, lightening, power surges, or acts of God. Use of any other than Rogue Audio factory parts may void this warranty.

This warranty does not cover the cost of parts and labor which would be otherwise provided without charge under this warranty, obtained from any source other than Rogue Audio.

This warranty applies only to consumer use of this product and does not cover any product that is used in any trade or business, or in an industrial or commercial application.

This warranty applies only to the original purchaser of this product when purchased from an Authorized Rogue Audio dealer.

This warranty is valid only in the United States.

YOUR RIGHTS

ROGUE AUDIO LIMITS ITS OBLIGATIONS UNDER ANY IMPLIED WARRANTIES UNDER STATE LAWS TO A PERIOD NOT TO EXCEED THE WARRANTY PERIOD. SOME STATES DO NOT ALLOW LIMITATIONS ON HOW LONG AN IMPLIED WARRANTY LASTS, AND SOME STATES DO NOT ALLOW THE EXCLUSION OR LIMITATION OF INCIDENTAL OR CONSEQUENTIAL DAMAGES, SO THE ABOVE LIMITATIONS OR EXCLUSIONS MAY NOT APPLY TO YOU. THIS WARRANTY GIVES YOU SPECIFIC LEGAL RIGHTS, AND YOU MAY HAVE OTHER RIGHTS WHICH MAY VARY FROM STATE TO STATE.

To Obtain Service

To obtain service, you must contact Rogue Audio and obtain a return authorization number. The product must be delivered to Rogue Audio in its original packaging prepaid at the following address:

**Rogue Audio Inc.
545 Jenna Dr.
Brodheadsville, PA 18322**